



CryoDuct™ MRISW Single-Wall MRI Quench Vent System

Delivering the certainty of zero-leak performance for MRI cryogenic exhaust applications

CryoDuct™ MRISW

Single-Wall MRI Quench Vent System

CryoDuct™ is the first and only prefabricated exhaust system designed specifically to meet the functional, structural and safety requirements of MRI quench vent applications.

With CryoDuct™, you get superior safety with zero leakage, unmatched quality for long-lasting structural integrity, plus made-in-the-USA quality and support.

System Concept

- Prefabricated, modular, single-wall system
- CPR bolt-together joint connection designed to ensure a leak-free system under positive or negative pressure.
- Each section is joined together and sealed by compressing a pressure and liquid-tight cryogenic gasket between the flanges, meaning no sealant or on-site welding is required on any connection.
- Bellows are installed on linear runs to handle the thermal contraction during a quench event.
- Each system is designed to provide the proper termination option (capped roof, discharge cone or box) to safely expel cryogenic helium gas.

Material Thickness

The standard 304 stainless steel liner thickness is 0.036".

Complete Line of Fittings and Sizes Available

- Even/odd diameters from 5" - 24" standard
- Standard components: straight sections, contraction joints, elbows, terminations, roof-penetration components, support members
- Special order components: virtually any custom fittings

Material Available

The CryoDuct™ MRISW system is available in non-magnetic type 304 stainless-steel.

Surroundings

- MRISW is suitable for use with MRI machines which exhaust cryogenic helium gas not exceeding -452.47°F (-269.15°C) during a system quench
- System is to be installed as required by the MRI manufacturer
- Ducts are intended to be installed unenclosed or with non-freezable enclosures
- Freezable materials should not be closer than 12" to duct wall

Support Limits

Support plates and wall supports are utilized to support the weight of the exhaust system and to provide a fixed point to allow proper operation of contraction joints. In horizontal runs, supports should be placed adjacent to fittings not otherwise supported. See the individual part description for allowable support charts.

Tests Performed

The CryoDuct™ MRISW system has endured rigorous tests that include the following:

- **STRUCTURAL TESTS**

The support plates have been tested to maintain up to a four times safety rating against the listed load.

- **WIND LOAD TESTS**

Loads equivalent to 110 mph wind have been applied to the exhaust system with acceptable results.

CryoDuct™ Value

- **FAST PROJECT COMPLETION**

- Short lead times
- Trouble-free installation / detailed instructions
- No on-site welding

- **MAXIMUM STRENGTH / LONG LIFE**

- Unmatched dimensional accuracy for secure joint connections
- Fully welded liners
- Unequaled support limits

- **COMPLETE SYSTEM DESIGN**

- CAD drawings
- 3D design solutions
- Complete BOM
- System sizing

- **SPECIAL FITTINGS**

- Customized components are available to meet the needs of your specific project



Part Numbers

All standard parts manufactured by CryoDuct™ are identified by a part number that describes their makeup and function.

The part numbers are made up as follows.

1. The first series is the model designation, MRISW.
2. This is followed by the part name. For example, 47S, 90L or TI.
3. Next is the part's internal diameter in inches, such as 06, 12 or 24.
4. Last is the material designation.

For example, the part number for a Model MRISW (MRISW), 47" long Straight Section (47S), 8" ID (08), with a 304 stainless-steel liner is MRISW-47S-08C.

CODE	MATERIAL
C	304 Stainless Steel *
J	304 Stainless Steel **
F	Galvanized Steel
H	Painted Carbon Steel

* Specifies that supports and accessories are non-stainless steel, with hardware featuring a zinc coating

** Specifies that all supports and accessories are 304 stainless steel

Joint Assembly

1. Clean flanges and inner side of bolt flange with mineral spirits in order to remove any oil or dirt residue.
2. Apply the provided patterned PTFE gasket to the bolt flange.
3. Join the two flanged ends of the sections.
4. Install the provided hardware to join the bolt flanges together, tightening the bolts in a star pattern at torque specifications of 12 lb-ft.

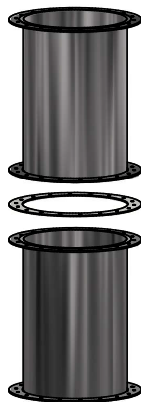

STEP 1



STEP 2

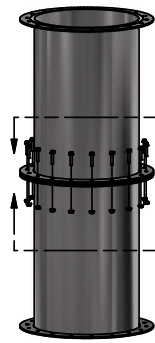

STEP 3

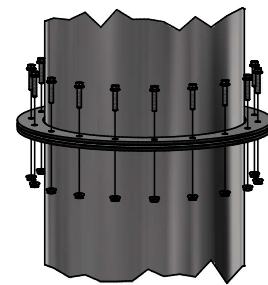

STEP 3 CLOSE

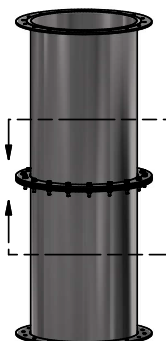

STEP 4

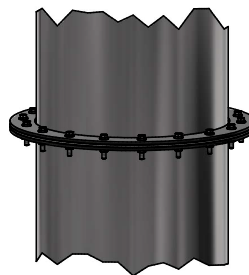

STEP 4 CLOSE

SYSTEM COMPONENTS

Custom dimensions are available to suit your needs in even and odd sizes.

150# Flange Adapter Kit

Part No. ANAK

The 150# Flanged Adapter Kit is used to connect to a flanged appliance outlet. It is patterned to match a standard ANSI 150# bolt flange and comes welded to a 4" tube section.

Includes hardware corresponding to the bolt pattern and flange material of the adapter.

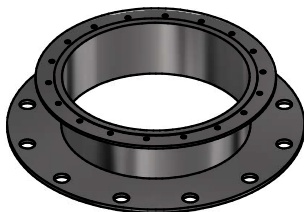
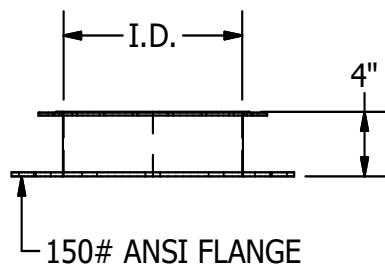

Waveguides

MRI rooms are shielded to block radiofrequency (RF) interference, ensuring clear imaging and protecting personnel from harmful RF exposure. Waveguides provide RF-transparent channels, allowing essential services to pass through the shield without undermining its integrity. Integrated into the quench vent system, a waveguide safely directs cryogenic helium gas to the outside during a quench while preserving the RF shielding effectiveness.

CryoDuct™ does not supply the waveguide but will supply the means to connect to the component. The connection will vary depending on the waveguide.

Waveguides are typically provided by the MRI manufacturer or the RF shielding vendor.



SYSTEM COMPONENTS

Custom dimensions are available to suit your needs in even and odd sizes.

Straight Section

Part No. 18S, 29S, 47S and 59S

Standard lengths are as follows:

Diameter 5" to 7" are 18", 29" and 47"

Diameter 8" to 24" are 18", 29", 47" and 59"

Custom parts can be manufactured to any length over 2".

Includes one PTFE gasket.

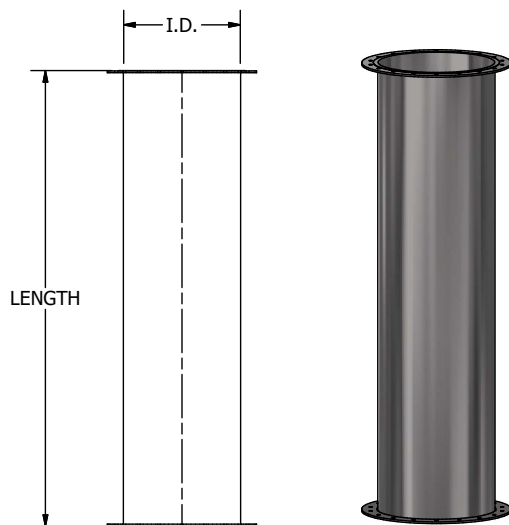

PART NO. 18S / 29S / 47S / 59S	
	I.D.
	6"
	8"
	10"
	12"
	14"
	16"
	18"
	20"
	22"
	24"

Bellows Section

Part No. BS

The Bellows Section is designed to compensate for thermal contraction, up to 2".

Includes one PTFE gasket.

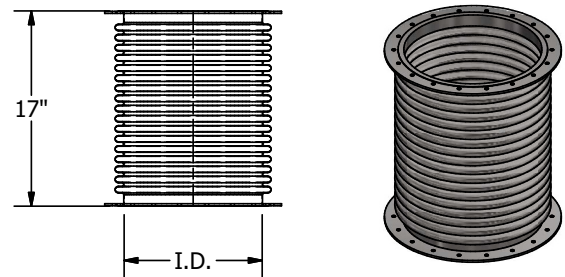

PART NO. BS	
	I.D.
	6"
	8"
	10"
	12"
	14"
	16"
	18"
	20"
	22"
	24"

SYSTEM COMPONENTS

Custom dimensions are available to suit your needs in even and odd sizes.

Tapered Increaser

Part No. TI

The Tapered Increaser is used when a change in pipe diameter is required.

Includes one PTFE gasket of both smaller and larger sizes.

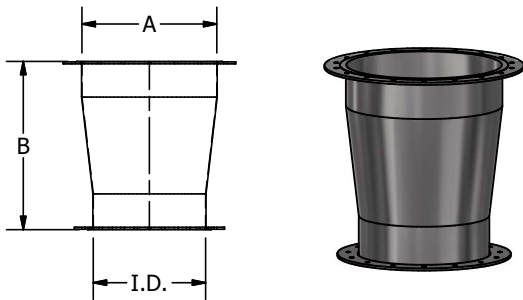

Eccentric Tapered Increaser

Part No. ETI

The Eccentric Tapered Increaser is used when a change in pipe diameter is required and maintains an eccentric profile when it is necessary for the pipe to be flat on one side.

Includes one PTFE gasket of both smaller and larger sizes.

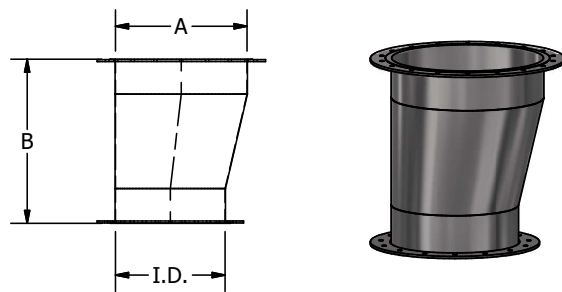

PART NO. TI / ETI

I.D.	A	B	A	B	A	B	A	B
6"	8"	15"	10"	18"	12"	21"	14"	24"
8"	10"	15"	12"	18"	14"	21"	16"	24"
10"	12"	15"	14"	18"	16"	21"	18"	24"
12"	14"	15"	16"	18"	18"	21"	20"	24"
14"	16"	15"	18"	18"	20"	21"	22"	24"
16"	18"	15"	20"	18"	22"	21"	24"	24"
18"	20"	15"	22"	18"	24"	21"	-	-
20"	22"	15"	24"	18"	-	-	-	-
22"	24"	15"	-	-	-	-	-	-
24"	-	-	-	-	-	-	-	-

Available in odd sizes. Call for odd diameter taper increaser information.

SYSTEM COMPONENTS

Custom dimensions are available to suit your needs in even and odd sizes.

End Cap

Part No. EC

The End Cap is used to close an unused opening and to provide a means of accessing the interior of the system for inspection and cleaning.

Includes one PTFE gasket.

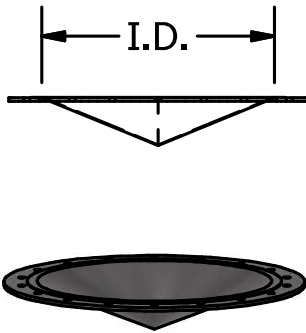

PART NO. EC	
I.D.	
6"	
8"	
10"	
12"	
14"	
16"	
18"	
20"	
22"	
24"	

Original 90° Elbow

Part No. 090L

The Original 90° Elbow is used when making a directional change. The 090L is available in sizes 6" through 24".

Includes one PTFE gasket.

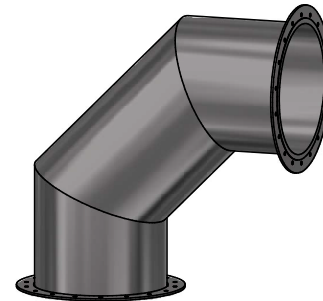
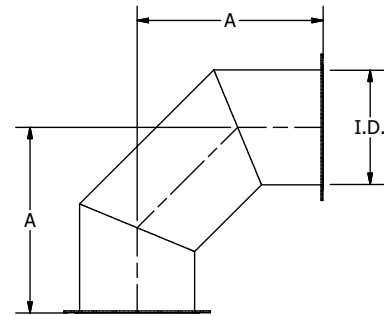

PART NO. 090L		
I.D.		A
6"		13 1/2"
8"		15 1/2"
10"		17 1/2"
12"		19 1/2"
14"		21 1/2"
16"		23 1/2"
18"		25 1/2"
20"		27 1/2"
22"		29 1/2"
24"		31 1/2"

SYSTEM COMPONENTS

Custom dimensions are available to suit your needs in even and odd sizes.

45° Elbow

Part No. 45L

The 45° Elbow is used when a vertical or horizontal direction change of 45° is desired.

Includes one PTFE gasket.

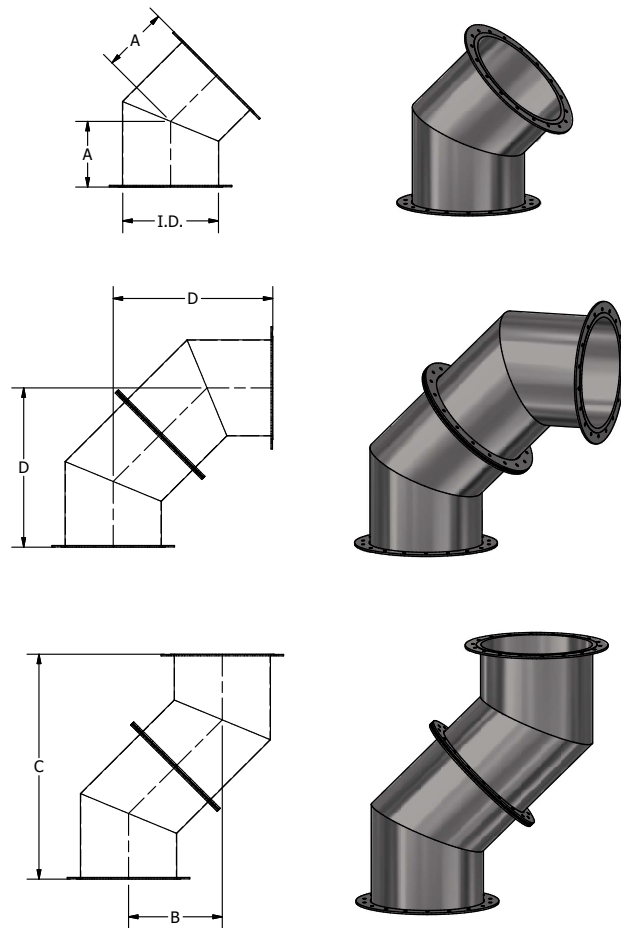

PART NO. 45L

I.D.	A	B	C	D
6"	7"	9 29/32"	23 29/32"	16 29/32"
8"	7 3/8"	10 7/16"	25 3/16"	17 13/16"
10"	7 3/16"	11 3/64"	26 43/64"	18 55/64"
12"	8 1/4"	11 43/64"	28 11/64"	19 59/64"
14"	8 5/8"	12 13/64"	29 29/64"	20 53/64"
16"	9 1/16"	12 13/16"	30 15/16"	21 7/8"
18"	9 1/2"	13 7/16"	32 7/16"	22 15/16"
20"	9 7/8"	13 31/32"	33 23/32"	23 27/32"
22"	10 5/16"	14 37/64"	35 13/64"	24 57/64"
24"	10 3/4"	15 13/64"	36 45/64"	25 61/64"

30° Elbow

Part No. 30L

The 30° Elbow is used when a vertical or horizontal direction change of 30° is desired.

Includes one PTFE gasket.

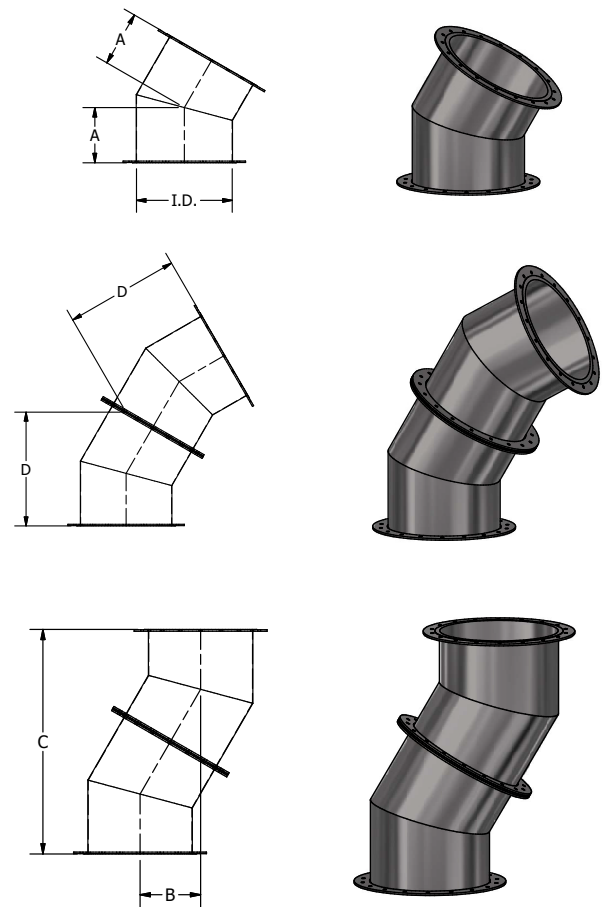

PART NO. 30L

I.D.	A	B	C	D
6"	6 1/8"	6 1/8"	22 55/64"	13 13/64"
8"	6 3/8"	6 3/8"	23 51/64"	13 47/64"
10"	6 5/8"	6 5/8"	24 23/32"	14 9/32"
12"	6 15/16"	6 15/16"	25 57/64"	14 61/64"
14"	7 3/16"	7 3/16"	26 53/64"	15 31/64"
16"	7 7/16"	7 7/16"	27 3/4"	16 1/32"
18"	7 3/4"	7 3/4"	28 59/64"	16 45/64"
20"	8"	8"	29 55/64"	17 15/64"
22"	8 1/4"	8 1/4"	30 51/64"	17 23/32"
24"	8 1/2"	8 1/2"	31 23/32"	18 5/16"

SYSTEM COMPONENTS

Custom dimensions are available to suit your needs in even and odd sizes.

Flashing

Part No. FL

The Flashing is used in conjunction with the rain collar to seal roof penetrations. This part is designed for flat roofs. Custom-pitched flashings are available upon request.

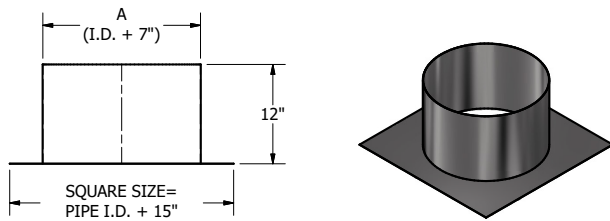

Full Ring

Part No. FR

The Full Ring is used to guide horizontal and vertical runs. The part is simply bolted around the outer shell and then rigidly connected to the building structure.

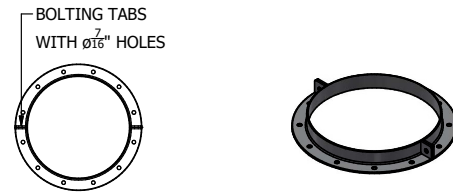

Insulated Thimble

Part No. IT

The Insulated Thimble is used when penetrating a freezable wall or roof. This part is designed for flat roofs. Custom pitched thimbles are available upon request.

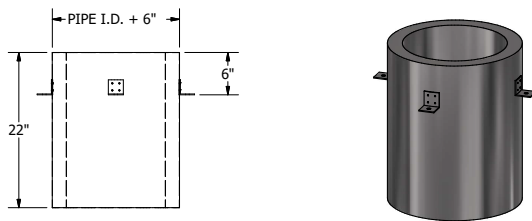

Floor/Roof Guide

Part No. FRG

The Floor/Roof Guide is used at the penetration of floors and roofs to guide the exhaust flue. This part is designed to absorb lateral loads only. It will not support vertical exhaust system sections.

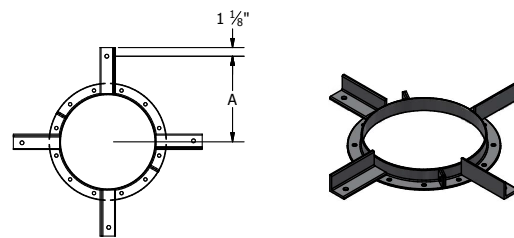

Rain Collar

Part No. RC

The Rain Collar is used in conjunction with the flashing to seal roof penetrations.

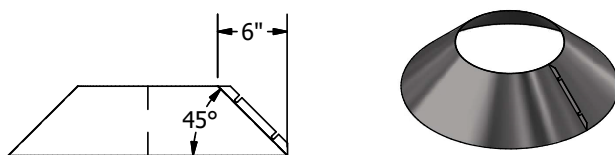

PART NO. FRG

I.D.	A
6"	9 3/8"
8"	10 3/8"
10"	11 3/8"
12"	12 3/8"
14"	13 3/8"
16"	14 3/8"
18"	15 3/8"
20"	16 3/8"
22"	17 3/8"
24"	18 3/8"

SYSTEM COMPONENTS

Custom dimensions are available to suit your needs in even and odd sizes.

Support Plate

Part No. SP

The Support Plate is the primary load-carrying member of the exhaust system assembly. This part is designed to support (B) (see chart below) of vertical exhaust section, as well as provide fixed points in breeching runs. The support plate is made up of one plate welded to a 5-1/4" tube section.

Includes one PTFE gasket.

Note: This part must be placed at the connection of two flue sections.

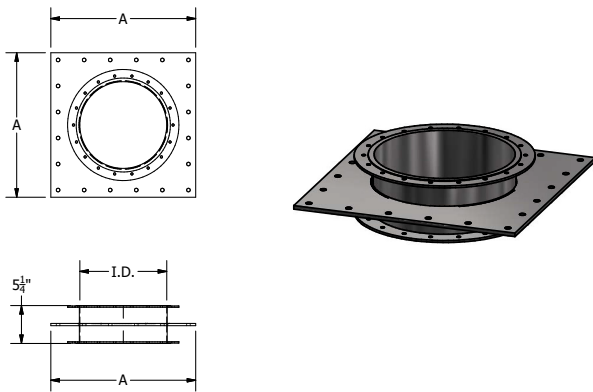

PART NO. SP		
I.D.	A	B (FT)
6"	12"	403'
8"	14"	389'
10"	16"	375'
12"	18"	361'
14"	20"	347'
16"	22"	334'
18"	24"	320'
20"	26"	306'
22"	28"	292'
24"	30"	278'

Wall Support / Wall Guide

Part No. WS / WG

The Wall Support and Wall Guide are used to guide long vertical runs that are placed adjacent to walls.

These parts maintain proper clearance to freezables when properly installed. Wall supports and/or wall guides are made custom and only available upon request.

Guy Section

Part No. GS

The Guy Section is used when the exhaust system extends beyond the vertical limits above the roof line. The guy section should be connected to guy wires or a rigid guying structure. The guy section is made up of one rounded guying plate welded to a 5-1/4" tube section.

Includes one PTFE gasket.

Note: This part must be placed at the connection of two flue sections.

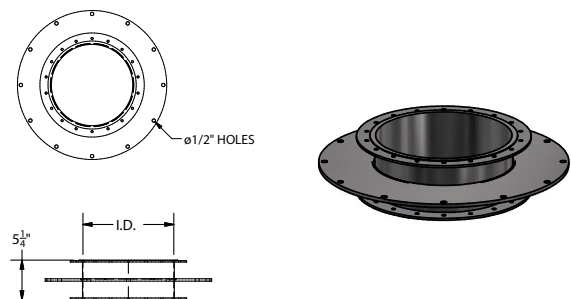

SYSTEM COMPONENTS

Custom dimensions are available to suit your needs in even and odd sizes.

Box Discharge

Part No. BDC

Designed for secure ground-level horizontal terminations, the box termination features a screen system to safely disperse cryogenic gas droplets, preventing injury or property damage. This termination should be mounted and installed in a designated, protected area with clear signage, ensuring the outlet vent is directed away from the building.

Includes one PTFE gasket.

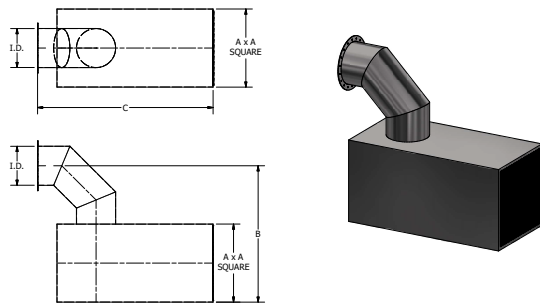

Discharge Cone

Part No. DCC

The Discharge Cone is engineered for horizontal discharges on second-story or above installations. Its conical design facilitates controlled gas expansion while effectively preventing rain ingress, ensuring reliable performance in elevated, sidewall termination applications. The cone outlet should be oriented in a direction that avoids contact with nearby building materials or personnel, minimizing the risk of cryogenic vapor exposure.

Includes one PTFE gasket.

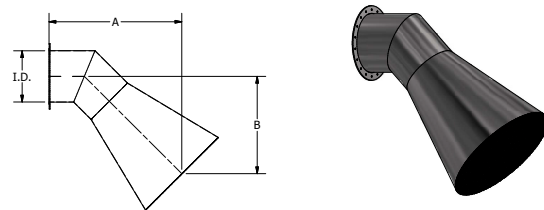

PART NO. BDC			
I.D.	A	B	C
5"	10"	17 1/2"	22 1/2"
6"	12"	21"	27"
7"	14"	24 1/2"	31 1/2"
8"	16"	28"	36"
9"	18"	31 1/2"	40 1/2"
10"	20"	35"	45"
11"	22"	38 1/2"	49 1/2"
12"	24"	42"	54"
13"	26"	45 1/2"	58 1/2"
14"	28"	49"	63"
15"	30"	52 1/2"	67 1/2"
16"	32"	56"	72"
17"	34"	59 1/2"	76 1/2"
18"	36"	63"	81"
19"	38"	66 1/2"	85 1/2"
20"	40"	70"	90"
21"	42"	73 1/2"	94 1/2"
22"	44"	77"	99"
23"	46"	80 1/2"	103 1/2"
24"	48"	84"	108"

PART NO. DCC		
I.D.	A	B
5"	19"	12"
6"	20 7/16"	13 7/16"
7"	22 1/2"	15 1/8"
8"	23 7/8"	16 1/2"
9"	26 1/16"	18 1/4"
10"	27 1/2"	19 11/16"
11"	29 5/8"	21 3/8"
12"	31 1/16"	22 13/16"
13"	33 1/8"	24 1/2"
14"	34 1/2"	25 7/8"
15"	36 11/16"	27 5/8"
16"	38 1/8"	29 1/16"
17"	40 1/4"	30 3/4"
18"	41 11/16"	32 1/4"
19"	43 3/4"	33 7/8"
20"	45 1/8"	35 1/4"
21"	47 5/16"	37"
22"	48 27/40"	38 3/8"
23"	50 7/8"	40 1/8"
24"	52 5/16"	41 9/16"

SYSTEM COMPONENTS

Custom dimensions are available to suit your needs in even and odd sizes.

Capped Roof Termination

Part No. CRT

Designed for vertical rooftop terminations, the capped roof termination effectively prevents wildlife intrusion and rainwater ingress, while integrated baffling safely disperses cryogenic gases to protect nearby roofing components. The rooftop discharge facilitates safe and effective gas dispersion to protect sensitive equipment while preserving the aesthetic and structural integrity of the building's sidewall architecture.

Includes one PTFE gasket.

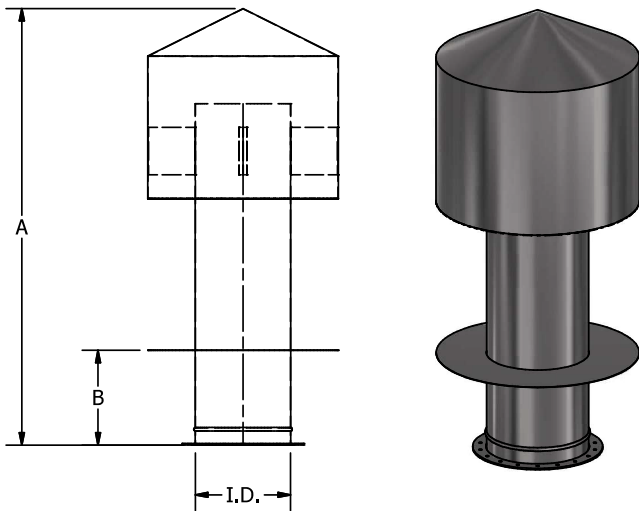

PART NO. CRT

I.D.	A	B
5"	23"	5"
6"	27 5/8"	6"
7"	32 3/16"	7"
8"	36 13/16"	8"
9"	41 3/8"	9"
10"	46"	10"
11"	50 5/8"	11"
12"	55 3/16"	12"
13"	59 13/16"	13"
14"	64 3/8"	14"
15"	69"	15"
16"	73 5/8"	16"
17"	78 3/16"	17"
18"	82 13/16"	18"
19"	87 3/8"	19"
20"	92"	20"
21"	96 5/8"	21"
22"	101 3/16"	22"
23"	105 13/16"	23"
24"	110 3/8"	24"



SYSTEM COMPONENTS

Custom dimensions are available to suit your needs in even and odd sizes.

CryoDuct™ MRISW Weight Chart

Part Description	Part No.	INSIDE DIAMETER (INCHES)									
		6"	8"	10"	12"	14"	16"	18"	20"	22"	24"
18" Straight Section	18S	4 lbs	5	6	7	8	9	10	11	12	13
29" Straight Section	29S	8 lbs	10	12	14	16	18	21	23	25	27
30 Degree Elbow	30L	4 lbs	5	6	8	9	10	12	13	15	17
45 Degree Elbow	45L	5 lbs	6	7	9	10	12	14	16	18	20
47" Straight Section	47S	12 lbs	15	18	22	25	28	31	34	38	41
59" Straight Section	59S	-	19	23	27	31	35	39	43	47	51
90 Degree Elbow	90L	6 lbs	9	12	15	19	23	28	33	38	44
Bellows Section	BS	13 lbs	8	10	11	13	15	16	18	20	21
End Cap	EC	4 lbs	3	3	4	4	5	6	7	8	9
Flashing	FL	11 lbs	6	7	8	8	9	10	11	11	12
Floor/Roof Guide	FRG	10 lbs	5	6	6	8	8	9	9	10	12
Full Ring	FR	2 lbs	2	3	3	5	5	6	6	7	9
Guy Section	GS	5 lbs	6	7	7	8	9	10	11	12	13
Insulated Thimble	IT	10 lbs	11	13	14	16	17	18	20	21	22
Rain Collar	RC	2 lbs	3	3	3	3	4	4	4	4	5
Support Plate	SP	16 lbs	18	21	24	27	29	32	35	38	50
Tapered Increaser	TI	7 lbs	8	10	12	14	15	17	19	20	22
Capped Roof Termination	CRT	16 lbs	24	38	56	76	98	124	152	184	218
Box Discharge	BDC	19 lbs	32	50	69	95	124	155	192	231	274
Discharge Cone	DCC	11 lbs	19	28	41	55	73	92	112	137	161

All weights shown above are actual weights; for shipping weights, multiply by 1.25

Sample Specification

MRISW

The factory-built modular quench vent system shall be sealed with a compressed PTFE gasket joined between two bolt flanges.

Flue material shall be Type 304 stainless steel. Flue material thickness shall be 0.036" for 5" to 24" diameter systems. All flue seams shall be full penetration welded the entire length of the pipe section. Riveted, tack or spot-welded seams are not permitted.

Ducts are to terminate a minimum of 3' (0.92 m) above the highest point of the roof penetration and 2' (0.61m) minimum above any portion of a building within 10' (3.1 m) horizontally.

After installation, non-stainless steel metal parts exposed to outdoor weather conditions should be protected by a minimum of one base coat and one finish coat of corrosion resistant paint.

Limited Lifetime Warranty CryoDuct™ Quench Vent Applications

CryoDuct™ warrants its MRISW model products installed in MRI quench vent applications against defects in material and workmanship in normal use for ten (10) years from the date of delivery to the construction site when installed, maintained and used as part of a CryoDuct™ MRISW duct system and in accordance with CryoDuct™ specifications, and is properly connected to a code compliant MRI ventilation system for quench vent applications. CryoDuct™ further warrants any portion of the exhaust system repaired or replaced under this warranty for the remainder of the original warranty period.

This warranty is limited to repair or replacement of the product plus shipping cost to the failure location. This warranty does not cover any labor costs for removal or replacement of the defective product, nor does this warranty cover any system components not furnished by CryoDuct™ and installed as part of the system.

This limited warranty is extended to the purchaser subject to the satisfaction of the following conditions:

1. System sizing and design has been performed by CryoDuct™ personnel and design parameters provided to CryoDuct™ by the responsible engineer were and are accurately representative of the operating conditions.
2. The undamaged components have been correctly installed in accordance with system design and sizing as performed by CryoDuct™ and installation instructions published by CryoDuct™ at the time of shipment.
3. Proper precautions have been taken to ensure that appliance air is free of solvent or refrigerant vapors or any halogenated compound which may cause acid condensate to form within the exhaust flue.
4. CryoDuct™ has supplied the entire duct or exhaust system from the appliance outlet to the termination of the stack.

CryoDuct™ makes no other warranty, whether expressed or implied. This warranty shall be the sole and exclusive remedy of any Buyer, whether in contract, tort or otherwise. UNDER NO CIRCUMSTANCES SHALL CRYODUCT BE LIABLE FOR ANY INCIDENTAL OR CONSEQUENTIAL DAMAGE, OR COMMERCIAL LOSS OR FROM ANY OTHER LOSS OR DAMAGE EXCEPT AS SET FORTH HEREIN. CryoDuct™ assumes no liability for any damages resulting in whole or part from misuse, improper installation or inadequate maintenance of the system or component part thereof, nor assumes or authorizes any other person or entity to assume on its behalf any other liability in connection with the sale of its products.



CryoDuct™ MRISW Single-Wall MRI Quench Vent System

Made of heavy-gauge steel, the factory-fabricated MRISW Single-Wall Quench Vent is designed for tight spaces. It yields zero-leakage under positive or negative pressure without any additional sealant or on-site welding required. This ensures a consistent, efficient and dependable installation every time.

CryoDuct™ products are built to withstand the catastrophic event of a quench while providing long-lasting structural integrity and zero-leak safety. Our deep application expertise helps ensure our solutions meet all MRI manufacturer vent requirements. Each system, including our bellows section and termination components, is designed to provide the ultimate in safety and performance.

CryoDuct™ was created by a team of experienced engineers and venting professionals from The Schebler Company, the global leader in fabricating high-quality products, components and sub-assemblies.



Designed by the industry's most respected manufacturer of reliable prefabricated exhaust systems, CryoDuct™ provides reliability, durability and consistency that no other MRI quench vent design can match.

**VISIT OUR WEBSITE
TO LEARN MORE.**
CRYODUCT.COM

